

Copying of this document and giving it to other persons, and the use or communication of the contents thereof, are forbidden without express authority. All rights reserved.

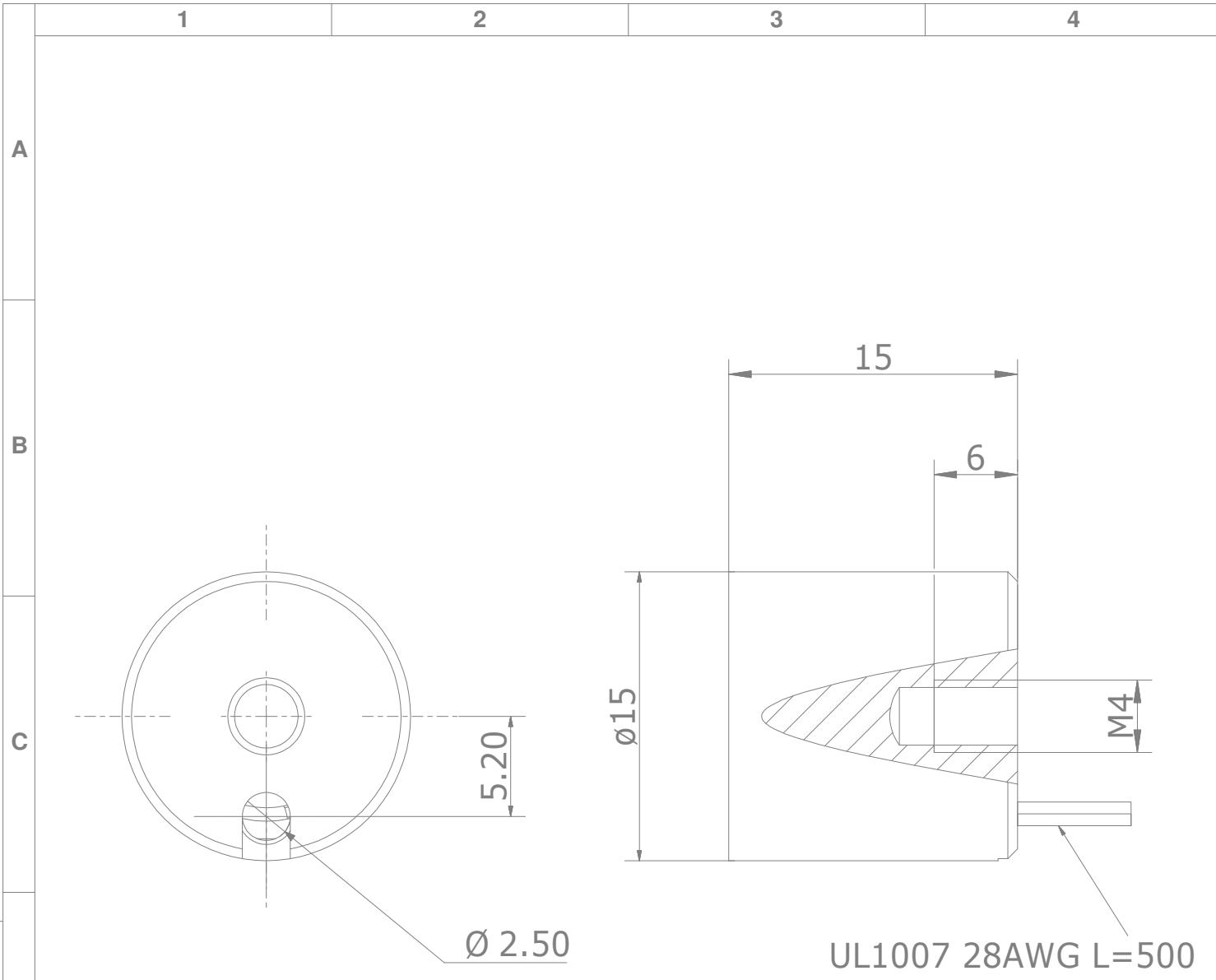

UL1007 28AWG L=500

NOTE:

1. 24VDC, 1,4W
2. 0mm stroke, Force >20N
3. Duty:100%

Weitergabe und Vervielfältigung dieser Unterlage, sowie Verwertung und Mitteilung ihres Inhalts nicht gestattet, soweit nicht ausdrücklich zugestanden. Alle Rechte vorbehalten.

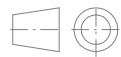
		Maße in mm Dimensions in millimeters		Zul. Abw. f. Maße ohne Toleranzang. General tolerances		Fertigzustand finished cond.		Maßstab Scale 1:2,5		Menge Quantity 1	
				ISO 2768-Km				Rohstoff/Raw material -		Rohteil-Nr./Raw piece No. -	
				2008		Datum Date 21.04.08		Name Name C. Franke		Elektromagnet	
				Bearb. Drawn		21.04.08		R. Mannel			
				Gepr. Check.		21.04.08					
				Norm Appr.							
								Sachnummer/Part-No.		Blatt Sheet 1	
								4140005		von of 1	
A		21.04.08		CF				Ursprung Source		MegaCAD	
Ausg. Issue		Änderung Modification		Datum Date		Name Name		Dateiname Filename			