

Copying of this document and giving it to others
 and the use or communication of the contents thereof
 are forbidden without express authority. All rights reserved.

Weitergabe und Vervielfältigung dieser Unterlage, sowie
 Verwendung und Mitteilung ihres Inhalts nicht gestattet,
 soweit nicht ausdrücklich zugestanden. Alle Rechte vorbehalten.

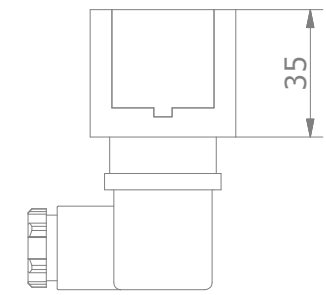
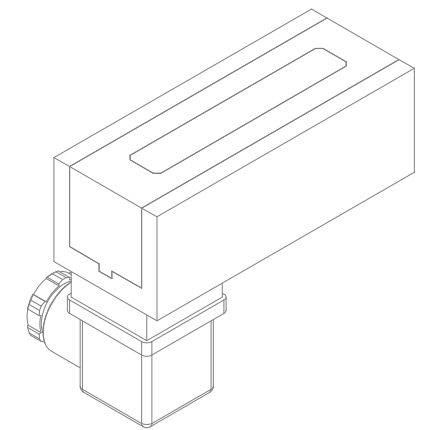
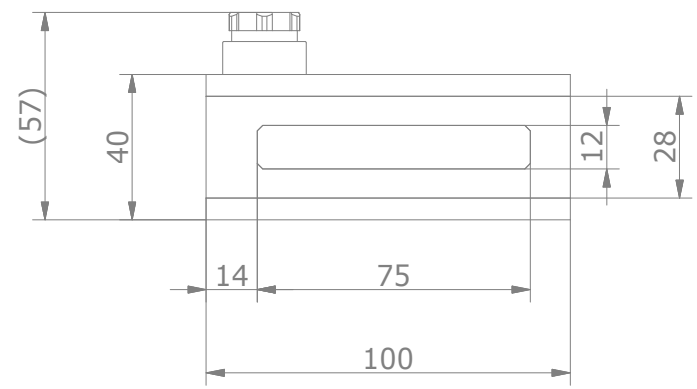
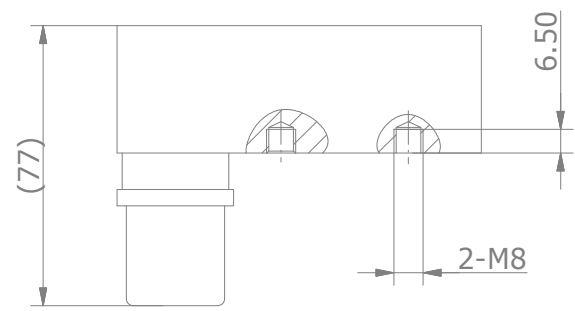
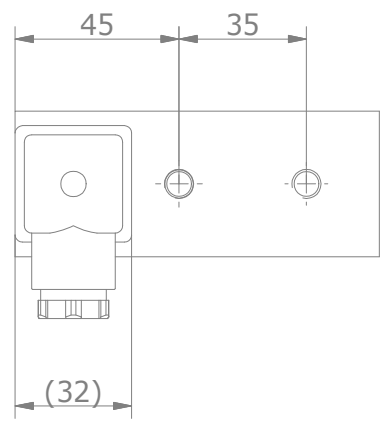

Artikelnummer						
4	3	4	0	1	1	0
1	2	3	4	5	6	7
Spannung:				↑		
230VAC				9		
205VDC				8		
24VDC				4		
Ausführung:						
St zn Leitung				0		
St zn Winkelstecker				1		
Edelstahlgehäuse				2		
Schutzplatte 1.4301				3		

	Maße in mm Dimensions in millimeters	Zul. Abw. f. Maße ohne Toleranzang. General tolerances	Fertigzustand finished cond.	Maßstab Scale 1:50	Menge Quantity 1
		ISO 2768-Km		Rohstoff/Raw material - Rohteil-Nr./Raw piece No. - Werkzeug-Nr./Tool No. -	
		Datum Date	Name Name	Benennung/Designation	
		Bearb. Drawn 01.07.09	R. Mannel	Elektromagnet 100% ED; 9W; 950N	
		Gepr. Check 01.07.09	C. Franke		
		Norm Appr.		Sachnummer/Part-No.	Blatt Sheet 1
				4340110	von of 1
		Ausg. Issue	Änderung Modification	Datum Date	Ursprung Source
				Name Name	Dateiname Filename
					MegaCAD